

# EQUIPMENT SHEET

## TERRA PLANA

WATER INJECTION DREDGER / MULTI PURPOSE VESSEL



### CONSTRUCTION/CLASSIFICATION

Year of delivery	2016
Classification	Bureau Veritas I ✕ HULL ✕ MACH ✕ AUT-UMS Special Service Unrestricted navigation Dynamic Positioning • DYNAPOS AM/AT

### FEATURES

Water Injection Vessel
Ploughboat
Active heave compensation
Moonpool

### MAIN DATA

Length overall	39.8 m
Length b.p.p.	35.93 m
Breadth	12 m
Moulded depth	4.1 m
Design draught	3.2 m
Max. dredging depth	30 m (can be extended to 40 m)
Min. dredging depth (WID)	5.2 m
Total installed power	3,423 kW
Jet pump output	12,000 m <sup>3</sup> /hr
Navigation speed	11 kn
Dynamic positioning system	DP Class 1 Make RH Marine
Main engines	2 x 746 kW (Caterpillar)
Thrusters	2 x 746 kW (Veth/Azimuth) 1 x 329 kW (Veth/Tunnel)
Crane	10 t at 20 m 2 x 25 t AHC
Hoist winches	2 x 25 t AHC
Plough winches	2 x 35 t

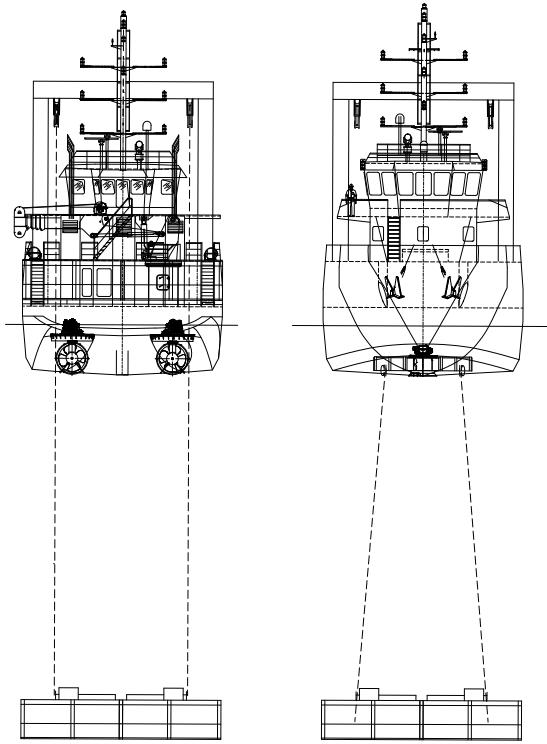

**FRONT AND AFT VIEW**

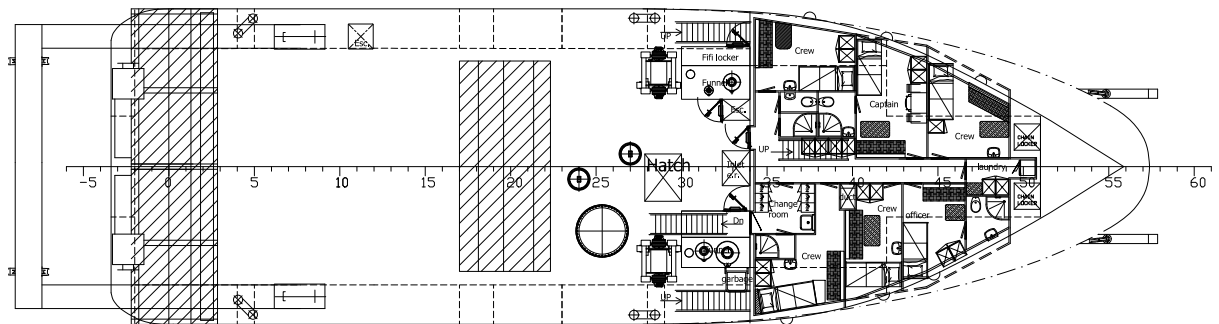

**TOP VIEW DECK LEVEL**