

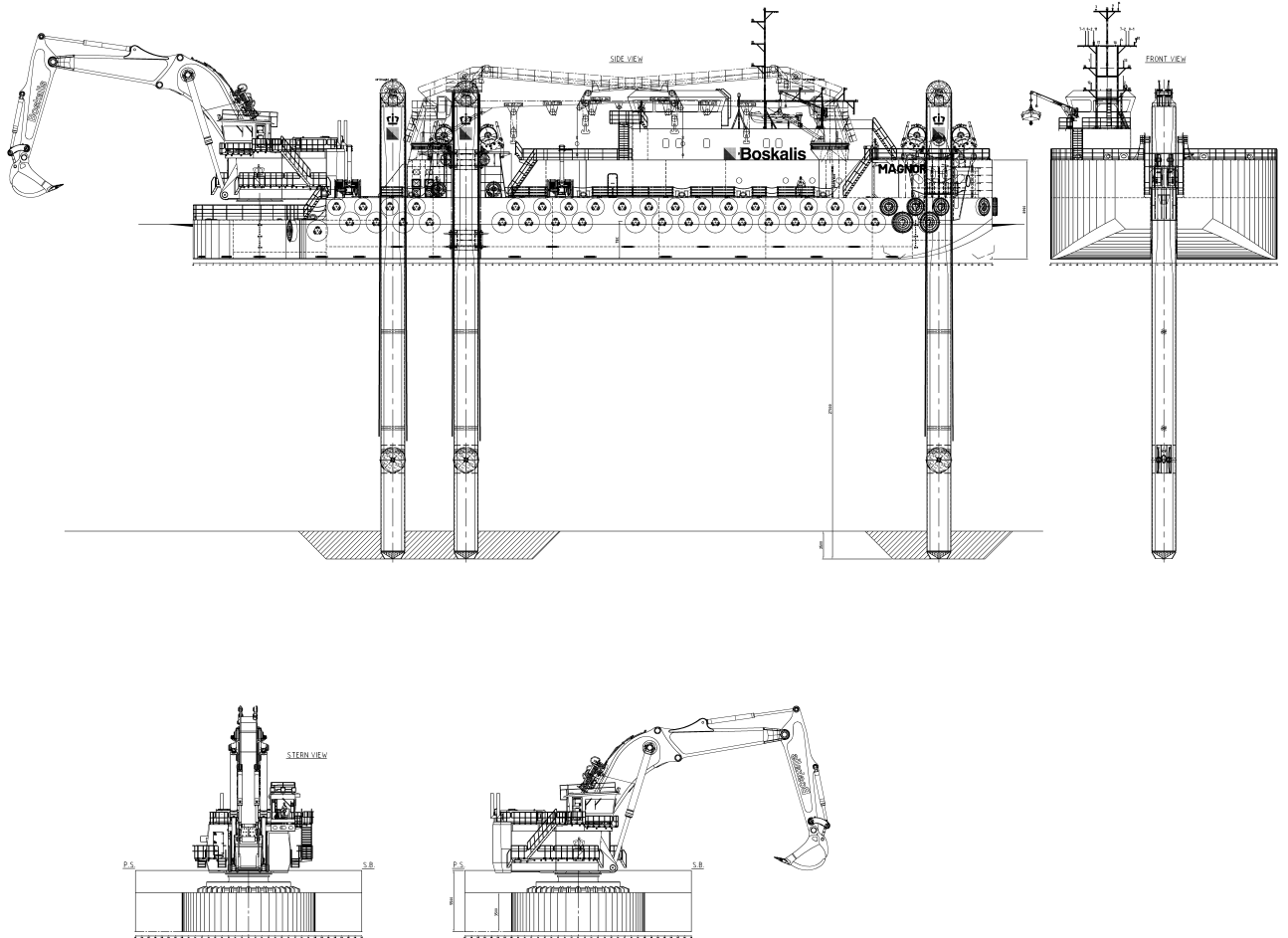

CONSTRUCTION / CLASSIFICATION

Vessel built by	Ravestein B.V.
Year of conversion	2015
Classification	Bureau Veritas unrestricted navigation, Green Passport

MAIN DATA

Gross tonnage	2,312 GT
Length overall	72 m
Moulded breadth	20.4 m (+1.5 m operational width (fenders))
Moulded depth	5.5 m
Normal draught	3.39 m
Spud length	40 m
Spud system	3 spuds/tilting spud
Type of excavator	BK 12700 DD Greenline
Bucket capacity	up to 40 m ³
Maximum dredging depth	22/27 m
Total installed power	4,100 kW
Excavator engine power	3,356 kW



SIDE VIEWS